

TECHNICAL DATASHEET

MA Multi Anchor CE7 polyester 2-component chemical anchor

EN
rev. 01/2018
p. 1/3

Certificates

ETA 16/0598 Certification for anchoring of threaded bars on non-cracked concrete (Option 7)
Complies with LEED® requirements, IEQ Credit 4.1
Class A+ for emission of volatile organic compounds (VOCs) in living spaces

Base Material

certified use	specific use	suitable use
non-cracked concrete	solid masonry hollow masonry natural stone (can stain)	AAC

Sizes

art.	content	mixer	gun
CC40	410 ml	CM12	CP01, CP11, CP15, CP16
CC30	300 ml	CM12	CP07
CC17	175 ml	CM12	CP07

Intended use

Dry non-cracked concrete

Cartridge temperature: between +5 and +25 °C

Installation temperature: between +5 and +35 °C

Work temperature: between -40 and +40 °C (maximum short term temperature +40 °C; long term +24 °C)

Shelf life: 18 months for 410 ml cartridges, 12 months for 300 ml and 175 ml cartridges (storage temperature between +5 and +25 °C)

Time and temperatures

temperature of base material	working time	full curing
+5 °C	15 min	120 min
+5 ÷ +10 °C	10 min	120 min
+10 ÷ +20 °C	5 min	80 min
+20 ÷ +30 °C	3 min	45 min
+30 ÷ +35 °C	1,5 min	25 min
+35 °C	1,5 min	20 min

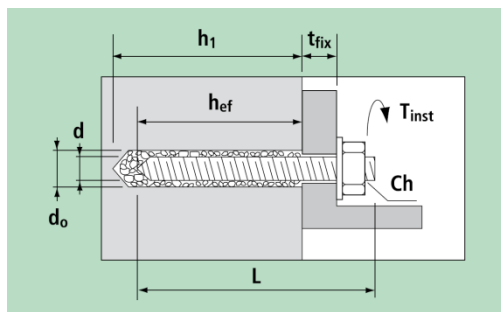

d = bar diameter
L = bar length
t_{fix} = fixable thickness
d₀ = hole diameter
h₁ = minimum hole depth
h_{nom} = setting depth
h_{ef} = effective anchorage depth
T_{inst} = tightening torque

use without sleeve: h_{ef} = h₁ = h_{nom}

• Use on concrete

Installation

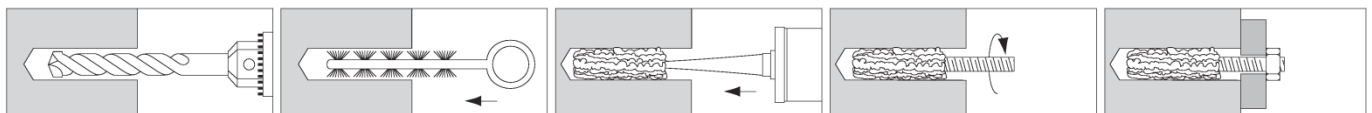

TECHNICAL DATASHEET
MA Multi Anchor CE7 polyester 2-component chemical anchor

 EN
 rev. 01/2018
 p. 2/3

Setting parameters

bar size		M8	M10	M12	M16	M20	M24
hole diameter	d ₀ mm	10	12	14	18	22	28
hole depth	h _{ef} mm	80	90	110	125	170	210
minimum spacing	s _{min} mm	40	50	60	80	100	120
minimum edge distance	c _{min} mm	40	50	60	80	100	120
min. base material thickness	h _{min} mm	110	120	140	160	215	260
tightening torque	T _{inst} Nm	10	20	40	80	150	200

Strength data

Valid for a single anchor far from the edges, on a thick concrete member of class C20/25.

Characteristic resistance (kN)

bar size		M8	M10	M12	M16	M20	M24
tension	N _{Rk}	18.0	29.0	35.0	60.0	75.0	115.0
shear	V _{Rk}	9.0	15.0	21.0	39.0	61.0	88.0

Design resistance (kN)

bar size		M8	M10	M12	M16	M20	M24
tension	N _{Rd}	12.0	19.3	19.4	33.3	41.7	63.9
shear	V _{Rd}	7.2	12.0	16.8	31.2	48.8	70.4

Recommended load (kN)

bar size		M8	M10	M12	M16	M20	M24
tension	N _{rec}	8.6	13.8	13.9	23.8	29.8	45.6
shear	V _{rec}	5.1	8.6	12.0	22.3	34.9	50.3

1 kN ≈ 100 kg

steel failure, class 5.8

 Characteristic resistances N_{Rk} and V_{Rk} derive from parameters certified in European Technical Assessment ETA 16/0589. Design resistances N_{Rd} e V_{Rd} include partial safety factors on strengths. Recommended values N_{rec} e V_{rec} include the further 1.4 safety factor.

 For the design of fixing with reduced spacing, near the edge or on concrete with increased resistance or reduced thickness refer to ETA 16/0589 or to Declaration of Performance DPGEB1026 and use the design method outlined in EOTA's *Technical Report 029*. One can also calculate and verify the fixings made with MA Multi Anchor by means of *G&B Calculation Program* available on the website www.gebfissaggi.com.

Parameters for design
Critical distances and spacing

bar size		M8	M10	M12	M16	M20	M24
critical spacing	s _{cr,N} mm	160	180	220	250	340	420
	s _{cr,sp} mm	320	360	440	375	510	630
critical edge distance	c _{cr,N} mm	80	90	110	125	170	210
	c _{cr,sp} mm	160	180	220	188	255	315

Increasing factors for concrete strength (excluding steel failure)

Ψ _c	C30/37	1.12
	C40/50	1.23
	C50/60	1.30

TECHNICAL DATASHEET

MA Multi Anchor CE7 polyester 2-component chemical anchor

 EN
 rev. 01/2018
 p. 3/3

- **Use on masonry** (not included in certification)

Installation

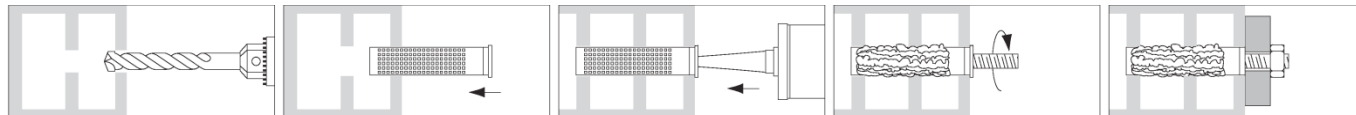

Setting parameters

bar size			M6	M8	M10	M12
use without sleeve on solid bricks	hole diameter	d_0 mm	8	10	12	16
	hole depth	h_{ef} mm	65	85	95	115
use with sleeve on solid or hollow bricks	sleeve		BR12x50	BR16x85	BR16x85	BR20x85
	hole diameter	d_0 mm	12	16	16	20
	hole depth	h_1 mm	55	90	90	90
tightening torque		T_{inst} Nm	3	6	6	6

brick types		solid brick	hollow brick
minimum spacing	s_{min} mm	100	200
minimum edge distance	c_{min} mm	200	250

Strength data

Valid for a single anchor far from the edges.

Recommended load on hollow brick (kN)

bar size		M8	M10	M12
tension	N_{racc}	0.65	0.65	0.65
shear	V_{racc}	1.60	1.60	1.60

Recommended load on solid brick (kN) tension, shear or oblique

resistance class f_b (N/mm ²)	M8	M10	M12	M16
20.5	1,4	2,9	4,0	5,0
7.0	0,6	1,3	2,0	3,0
3.5	0,5	0,9	1,1	-
2.8	0,4	0,7	0,9	-

Load values derive from tests conducted in G&B Fissaggi's laboratories according to international guidelines.